

**REQUEST FOR PROPOSALS**

<p><b>YOU ARE HEREBY INVITED TO SUBMIT A BID TO MEET THE REQUIREMENTS OF THE DEVELOPMENT BANK OF SOUTHERN AFRICA LIMITED</b></p>	
<p><b>BID NUMBER:</b></p>	<p><b>RFP124/2023</b></p>
<p><b>COMPULSORY BRIEFING SESSION DETAILS:</b></p>	<p>Briefing session will take place at the DBSA campus situated at 1258 LEVER ROAD, HEADWAYHILL, MIDRAND. Bidders must advise of their attendance by sending an email to <a href="mailto:tebogoSCM@dbsa.org">tebogoSCM@dbsa.org</a> and <a href="mailto:tebogoS2@dbsa.org">tebogoS2@dbsa.org</a> two (2) working days before the meeting to be invited.</p> <p><b>23 May 2023 @10H00 (Johannesburg time)</b></p>
<p><b>CLOSING DATE:</b></p>	<p><b>08 June 2023</b></p>
<p><b>CLOSING TIME:</b></p>	<p>23H55 (Midnight)</p>
<p><b>PERIOD FOR WHICH BIDS ARE REQUIRED TO REMAIN OPEN FOR ACCEPTANCE:</b></p>	<p>120 days</p>
<p><b>DESCRIPTION OF BID:</b></p>	<p><b>REPLACEMENT OF TWO UPS UNIT AND BATTERIES</b></p>
<p><b>BID DOCUMENTS ELECTRONIC SUBMISSION:</b></p>	<p><b>1. ELECTRONIC SUBMISSIONS</b></p> <p><b><u>INSTRUCTIONS:</u></b></p> <ul style="list-style-type: none"> <li>➤ Bidders are required to submit written requests for clarification via e-mail to <a href="mailto:tebogoSCM@dbsa.org">tebogoSCM@dbsa.org</a> <b>ONLY</b>, quoting the RFP Number on the subject of the e-mail.</li> <li>➤ Bidders will thereafter receive a OneDrive Link to upload their submission documents electronically.</li> <li>➤ Written requests for clarification will be considered up to and including <b>05 June 2023 16:00</b> Johannesburg time. Requests received after this date may not be attended to.</li> <li>➤ Any requests after the stipulated date and time may be disregarded.</li> </ul> <p><b>NB: Electronic submission is encouraged for all bidders interested in this tender</b></p> <p><b>Closing date of this RFP124.2023 is 08 June 2023 before 23:55. No physical bids will be received or accepted at the DBSA offices</b></p>

<b>NAME OF BIDDER:</b>	
<b>CONTACT PERSON:</b>	
<b>EMAIL ADDRESS:</b>	
<b>TELEPHONE NUMBER:</b>	
<b>FAX NUMBER:</b>	
<b>BIDDER'S STAMP OR SIGNATURE</b>	



The Development Bank of Southern Africa has a Zero Tolerance on Fraud and Corruption. Report any incidents of Fraud and Corruption to Whistle Blowers on any of the following:

TollFree : 0800 20 49 33  
 Email : [dbsa@whistleblowing.co.za](mailto:dbsa@whistleblowing.co.za)  
 Free Post : Free Post KZN 665 | Musgrave | 4062  
 SMS : 33490

## Table of Contents

<b>PART A</b> .....	<b>4</b>
<b>PART B</b> .....	<b>7</b>
<b>PART C</b> .....	<b>9</b>
<b>PART D</b> .....	<b>11</b>
<b>PART E</b> .....	<b>30</b>
<b>Annexure A</b> .....	<b>40</b>
<b>Annexure B</b> .....	<b>41</b>
<b>Annexure C</b> .....	<b>44</b>
<b>Annexure D</b> .....	<b>51</b>
<b>Annexure E</b> .....	<b>52</b>
<b>Annexure F</b> .....	<b>53</b>
<b>Annexure G</b> .....	<b>54</b>
<b>Annexure H</b> .....	<b>55</b>

**PART A  
INVITATION TO BID**

**YOU ARE HEREBY INVITED TO BID FOR REQUIREMENTS OF DEVELOPMENT BANK OF SOUTHERN AFRICA LIMITED ("DBSA")**

BID NUMBER: RFP124/2023

DESCRIPTION: REPLACEMENT OF TWO UPS UNIT AND BATTERIES.

COMPULSORY BRIEFING: 23 May 2023 at 10H00 (Johannesburg time)

COMPULSORY BRIEFING: Briefing session will take place at the DBSA campus situated at 1258 LEVER ROAD, HEADWAYHILL, MIDRAND. Bidders must advise of their attendance by sending an email to [tebogoSCM@dbsa.org](mailto:tebogoSCM@dbsa.org) and [tebogoS2@dbsa.org](mailto:tebogoS2@dbsa.org) two (2) working days before the meeting to be invited.

**23 May 2023 @10H00 (Johannesburg time)**

Time: 10H00 AM Johannesburg time (DBSA)

Closing time for the OneDrive Link submissions - 16h00 on the 05<sup>th</sup> of June 2023 (Telkom Time)

CLOSING DATE: **08 June 2023**

CLOSING TIME: 23H55

Name

 Bidder Name

Name

 Folder 1\_Financial Proposal

 Folder 2\_Technical Proposal

- a) It remains the bidder's responsibility to ensure that the bid submission is uploaded using the correct bidder document and tender link.
- b) Should a bidder encounter an issue with the system, the bidder must provide sufficient evidence as proof of attempting to upload their submission before the cut-off time and the error received.
- c) Faxed, emailed bids will not be accepted, only an electronic submission received via the link will be accepted.
- d) It is therefore the responsibility of the bidder to request for a link to participate.
- e) The DBSA assumes no responsibility if a Bidder's designated email address is not correct, or if there are technical challenges, including those with the Bidders computer, network, or internet service provider (ISP).

**BID SUBMISSION LINK REQUESTS:**

ALL BIDS MUST BE SUBMITTED ON THE OFFICIAL FORMS – (NOT TO BE RE-TYPED)

THIS BID IS SUBJECT TO THE GENERAL CONDITIONS OF CONTRACT (GCC) AND, IF APPLICABLE, ANY OTHER SPECIAL CONDITIONS OF CONTRACT, WHICH ARE SET OUT IN PART C OF THIS DOCUMENT.

THE FOLLOWING PARTICULARS MUST BE FURNISHED (FAILURE TO DO SO MAY RESULT IN YOUR BID BEING DISQUALIFIED).

BIDDERS THAT ARE UNINCORPORATED CONSORTIA CONSISTING OF MORE THAN ONE LEGAL ENTITY MUST SELECT A LEAD ENTITY AND FURNISH THE DETAILS OF THE LEAD ENTITY, UNLESS OTHERWISE SPECIFIED.

<b>NAME OF BIDDER AND EACH ENTITY IN CONSORTIUM:</b>				
<b>POSTAL ADDRESS:</b>				
<b>STREET ADDRESS:</b>				
<b>CONTACT PERSON (FULL NAME):</b>				
<b>EMAIL ADDRESS:</b>				
<b>TELEPHONE NUMBER:</b>				
<b>FAX NUMBER:</b>				
<b>BIDDER REGISTRATION NUMBER OR REGISTRATION NUMBER OF EACH ENTITY IN CONSORTIUM</b>				
<b>BIDDER VAT REGISTRATION NUMBER OR VAT REGISTRATION NUMBER OF EACH ENTITY IN CONSORTIUM</b>				
<b>BBBEE STATUS LEVEL VERIFICATION CERTIFICATE /BBBEE STATUS LEVEL SWORN AFFIDAVIT SUBMITTED?</b> <b>[TICK APPLICABLE BOX]</b>	<b>YES</b>		<b>NO</b>	

1..1.1	ARE YOU THE ACCREDITED REPRESENTATIVE IN SOUTH AFRICA FOR THE GOODS /SERVICES/WORKS OFFERED?	<input type="checkbox"/> Yes <input type="checkbox"/> No [IF YES ENCLOSE PROOF]		
1..1.2	ARE YOU A FOREIGN BASED SUPPLIER FOR THE GOODS /SERVICES/WORKS OFFERED?	<input type="checkbox"/> Yes <input type="checkbox"/> No [IF YES ANSWER PART B:3 BELOW ]		
1..1.3	SIGNATURE OF BIDDER			
1..1.4	DATE			
1..1.5	FULL NAME OF AUTHORISED REPRESENTATIVE			
1..1.6	CAPACITY UNDER WHICH THIS BID IS SIGNED (Attach proof of authority to sign this bid; e.g. resolution of directors, etc.)			
IF YES, WHO ISSUED THE CERTIFICATE?				
REGISTERED WITH THE NATIONAL TREASURY CSD [TICK APPLICABLE BOX]		YES	NO	
CSD REGISTRATION NUMBER				
TAX COMPLIANCE STATUS PIN (TCS) NUMBER ISSUED BY SARS				

**PART B  
TERMS AND CONDITIONS FOR BIDDING**

<b>1. BID SUBMISSION:</b>
<p>1.1. BIDS MUST BE SUBMITTED ELECTRONICALLY BY THE STIPULATED TIME TO THE LINK PROVIDED. LATE BIDS WILL NOT BE ACCEPTED FOR CONSIDERATION.</p> <p>1.2. ALL BIDS MUST BE SUBMITTED ON THE OFFICIAL FORMS PROVIDED – (NOT TO BE RE-TYPED)</p> <p>1.3. SOUTH AFRICAN BIDDERS MUST REGISTER ON THE CENTRAL SUPPLIER DATABASE (CSD) TO UPLOAD MANDATORY INFORMATION NAMELY: (BUSINESS REGISTRATION/ DIRECTORSHIP/ MEMBERSHIP/IDENTITY NUMBERS; TAX COMPLIANCE STATUS; AND BANKING INFORMATION FOR VERIFICATION PURPOSES). B-BBEE CERTIFICATE OR SWORN AFFIDAVIT FOR B-BBEE MUST BE SUBMITTED BY BIDDING INSTITUTION.</p> <p>1.4. WHERE A BIDDER IS NOT REGISTERED ON THE CSD, MANDATORY INFORMATION NAMELY: (BUSINESS REGISTRATION/ DIRECTORSHIP/ MEMBERSHIP/IDENTITY NUMBERS; TAX COMPLIANCE STATUS MUST BE SUBMITTED WITH THE BID DOCUMENTATION. B-BBEE CERTIFICATE OR SWORN AFFIDAVIT FOR B-BBEE MUST BE SUBMITTED TO BIDDING INSTITUTION.</p>
<b>2. TAX COMPLIANCE REQUIREMENTS</b>
<p>2.1 ALL BIDDERS MUST ENSURE COMPLIANCE WITH THEIR TAX OBLIGATIONS IN THEIR COUNTRY OF RESIDENCE.</p> <p>2.2 SOUTH AFRICAN BIDDERS ARE REQUIRED TO SUBMIT THEIR UNIQUE PERSONAL IDENTIFICATION NUMBER (PIN) ISSUED BY SARS TO ENABLE THE ORGAN OF STATE TO VIEW THE TAXPAYER’S PROFILE AND TAX STATUS.</p> <p>2.3 SOUTH AFRICAN BIDDERS CAN APPLY FOR TAX COMPLIANCE STATUS (TCS) OR PIN MAY ALSO BE MADE VIA E-FILING. IN ORDER TO USE THIS PROVISION, TAXPAYERS WILL NEED TO REGISTER WITH SARS AS E-FILERS THROUGH THE WEBSITE WWW.SARS.GOV.ZA.</p> <p>2.4 SA BIDDERS’ MAY ALSO SUBMIT A PRINTED TCS TOGETHER WITH THE BID.</p> <p>2.5 IN BIDS WHERE CONSORTIA / JOINT VENTURES / SUB-CONTRACTORS ARE INVOLVED; EACH PARTY MUST SUBMIT A SEPARATE PROOF OF TCS / PIN / CSD NUMBER (TAX COMPLIANCE) IN ACCORDANCE WITH APPLICABLE LEGISLATION IN THEIR COUNTRY OF RESIDENCE.</p> <p>2.6 WHERE SA BIDDERS HAVE NO TCS AVAILABLE BUT ARE REGISTERED ON THE CENTRAL SUPPLIER DATABASE (CSD), A CSD NUMBER MUST BE PROVIDED.</p>
<b>3. QUESTIONNAIRE TO BIDDING FOREIGN SUPPLIERS</b>
<p>3.1. IS THE BIDDER A RESIDENT OF THE REPUBLIC OF SOUTH AFRICA (RSA)? <input type="checkbox"/> YES <input type="checkbox"/> NO</p> <p>3.2. DOES THE BIDDER HAVE A BRANCH IN THE RSA? <input type="checkbox"/></p> <p>3.3. DOES THE BIDDER HAVE A PERMANENT ESTABLISHMENT IN THE RSA? <input type="checkbox"/> YES <input type="checkbox"/> NO</p> <p>3.4. DOES THE BIDDER HAVE ANY SOURCE OF INCOME IN THE RSA? <input type="checkbox"/> YES <input type="checkbox"/> NO</p> <p><b>IF THE ANSWER IS “NO” TO ALL OF THE ABOVE, THEN, IT IS NOT A REQUIREMENT TO OBTAIN A TAX COMPLIANCE STATUS / TAX COMPLIANCE SYSTEM PIN CODE FROM</b></p>

**THE SOUTH AFRICAN REVENUE SERVICE (SARS) AND IF NOT REGISTER AS PER 2.3 ABOVE.**

**NB: FAILURE TO PROVIDE ANY OF THE ABOVE PARTICULARS MAY RENDER THE BID INVALID.**

### **PART C**

#### **CHECKLIST OF COMPULSORY RETURNABLE SCHEDULES AND DOCUMENTS**

**Please adhere to the following instructions:**

- Tick in the relevant block below;
- Ensure that the following documents are completed and signed where applicable; and
- Use the prescribed sequence in attaching the annexes that complete the Bid Document

**NB:** Should all these documents not be included, the Bidder may be disqualified on the basis of non-compliance

**YES      NO**

           One original Bid document in separate folders; Folder 1 - for Pre-Qualifying Criteria and Functional Evaluation and Folder 2 - Price / Financial Proposal – **Electronic submission**

           **Part A:** Invitation to Bid

           **Part B:** Terms and Conditions of Bidding

           **Part C:** Checklist of Compulsory Returnable Schedules and Documents

           **Part D:** Conditions of Tendering and Undertakings by Bidders

           **Part E:** Specifications/Terms of Reference and Project Brief

           **Annexure A:** Price Proposal Requirement

           **Annexure B:** SBD4 Declaration of Interest

           **Annexure C:** SBD6.1 and B-BBEE status level certificate

           **Annexure F:** Certified copies of your CIPC company registration documents listing all members with percentages, in case of a lose corporation

           **Annexure G:** Certified copies of latest share certificates, in case of a company.

           **Annexure H: (if applicable):** A breakdown of how fees and work will be spread



between members of the bidding consortium.

**Annexure I:** Supporting documents to responses to Pre-Qualifying Criteria and Functional Evaluation Criteria.

**Annexure J:** General Condition of Contract

**Annexure K:** CSD Tax Compliance Status and Registration Requirements Report

## PART D

### CONDITIONS OF TENDERING AND UNDERTAKINGS BY BIDDER

#### 1. DEFINITIONS

In this Request for Proposals, unless a contrary intention is apparent:

- 1.1 **B-BBEE** means broad-based black economic empowerment as defined in section 1 of the Broad-Based Black Economic Empowerment Act, 2003;
- 1.2 **B-BBEE Act** means the Broad-Based Black Economic Empowerment Act, 2003;
- 1.3 **B-BBEE status level of contributor** means the B-BBEE status received by a measured entity based on its overall performance used to claim points in terms of regulation 6 and 7 of the Preferential Procurement Regulations, 2022.
- 1.4 **Business Day** means a day which is not a Saturday, Sunday or public holiday in South Africa.
- 1.5 **Bid** means a written offer in the prescribed or stipulated form lodged by a Bidder in response to an invitation in this Request for Proposal, containing an offer to provide goods, works or services in accordance with the Specification as provided in this RFP.
- 1.6 **Bidder** means a person or legal entity, or an unincorporated group of persons or legal entities that submit a Bid.
- 1.7 **Companies Act** means the Companies Act, 2008.
- 1.8 **Compulsory Documents** means the list of compulsory schedules and documents set out in Part B.
- 1.9 **Closing Time** means the time, specified as such under the clause **Error! Reference source not found.** (Bid Timetable) in Part C, by which Tenders must be received.
- 1.10 **DBSA** means the Development Bank of Southern Africa Limited.
- 1.11 **DFI** means Development Finance Institution.
- 1.12 **Evaluation Criteria** means the criteria set out under the clause 26 (Evaluation Process) of this Part C, which includes the Qualifying Criteria, Functional Criteria and Price and Preferential Points Assessment (where applicable).
- 1.13 **Functional Criteria** means the criteria set out in clause 27 of this Part C.
- 1.14 **Intellectual Property Rights** includes copyright and neighbouring rights, and all proprietary rights in relation to inventions (including patents) registered and unregistered trademarks (including service marks), registered designs, confidential information (including trade secrets

and know how) and circuit layouts, and all other proprietary rights resulting from intellectual activity in the industrial, scientific, literary or artistic fields.

- 1.15 **PFMA** means the Public Finance Management Act, 1999.
- 1.16 **PPPFA** means the Preferential Procurement Policy Framework Act, 2000.
- 1.17 **PPPFA Regulations** means the Preferential Procurement Regulations, 2022 published in terms of the PPPFA.
- 1.18 **Pre-Qualifying Criteria** means the criteria set out in clause 26.3 of this Part C.
- 1.19 **Price and Preferential Points Assessment** means the process described in clause 26.7 of this Part C, as prescribed by the PPPFA.
- 1.20 **Proposed Contract** means the agreement including any other terms and conditions contained in or referred to in this RFP that may be executed between the DBSA and the successful Bidder.
- 1.21 **Request for Proposal** or **RFP** means this document (comprising each of the parts identified under Part A, Part B, Part C and Part D) including all annexures and any other documents so designated by the DBSA.
- 1.22 **SARS** means the South African Revenue Service.
- 1.23 **Services** means the services required by the DBSA, as specified in this RFP Part D.
- 1.24 **SLA** means Service Level Agreement.
- 1.25 **SOE** means State Owned Enterprise, as defined by the Companies' Act.
- 1.26 **Specification** means the conditions of tender set and any specification or description of the DBSA's requirements contained in this RFP.
- 1.27 **State** means the Republic of South Africa.
- 1.28 **Statement of Compliance** means the statement forming part of a Tender indicating the Bidders compliance with the Specification.
- 1.29 **Tendering Process** means the process commenced by the issuing of this Request for Proposals and concluding upon formal announcement by the DBSA of the selection of a successful Bidder(s) or upon the earlier termination of the process.
- 1.30 **Website** means a website administered by DBSA under its name with web address [www.dbsa.org](http://www.dbsa.org)

## 2. INTERPRETATIONS

In this RFP, unless expressly provided otherwise a reference to:

- 2.1 "includes" or "including" means includes or including without limitation; and
- 2.2 "R" or "Rand" is a reference to the lawful currency of the Republic of South Africa.

## 3. TENDER TECHNICAL AND GENERAL QUERIES

Queries pertaining to this tender must be directed to:-

DBSA Supply Chain Management Unit

Email: [tebogoSCM@dbsa.org](mailto:tebogoSCM@dbsa.org)

No questions will be answered telephonically.

#### **4. SUBMISSION OF TENDERS**

**COMPULSORY BRIEFING: 23 May 2023 - Briefing session will take place at the DBSA campus situated at 1258 LEVER ROAD, HEADWAYHILL, MIDRAND. Bidders must advise of their attendance by sending an email to [tebogoSCM@dbsa.org](mailto:tebogoSCM@dbsa.org) and [tebogoS2@dbsa.org](mailto:tebogoS2@dbsa.org) two (2) working days before the meeting to be invited.**

Time: 10H00 AM Johannesburg time (DBSA)

CLOSING DATE: **08 June 2023**

CLOSING TIME: 23H55

#### **5. RULES GOVERNING THIS RFP AND THE TENDERING PROCESS**

- 5.1 Participation in the tender process is subject to compliance with the rules contained in this RFP Part C.
- 5.2 All persons (whether a participant in this tender process or not) having obtained or received this RFP may only use it, and the information contained herein, in compliance with the rules contained in this RFP.
- 5.3 All Bidders are deemed to accept the rules contained in this RFP Part C.
- 5.4 The rules contained in this RFP Part C apply to:
  - 5.4.1 The RFP and any other information given, received or made available in connection with this RFP, and any revisions or annexure;
  - 5.4.2 the Tendering Process; and
  - 5.4.3 any communications (including any briefings, presentations, meetings and negotiations) relating to the RFP or the Tendering Process.

#### **6. STATUS OF REQUEST FOR PROPOSAL**

- 6.1 This RFP is an invitation for person(s) to submit a proposal(s) for the provision of the services as set out in the Specification contained in this RFP. Accordingly, this RFP must not be construed, interpreted, or relied upon, whether expressly or implicitly, as an offer capable of acceptance by any person(s), or as creating any form of contractual, promissory or other rights. No binding contract or other understanding for the supply of services will exist between the DBSA and any Bidder unless and until the DBSA has executed a formal written contract with the successful Bidder.

#### **7. ACCURACY OF REQUEST FOR PROPOSAL**

- 7.1 Whilst all due care has been taken in connection with the preparation of this RFP, the DBSA makes no representations or warranties that the content in this RFP or any information communicated to or provided to Bidders during the Tendering Process is, or will be, accurate, current or complete. The DBSA, and its officers, employees and advisors will not be liable with respect to any information communicated which is not accurate, current or complete.
- 7.2 If a Bidder finds or reasonably believes it has found any discrepancy, ambiguity, error or inconsistency in this RFP or any other information provided by the DBSA (other than minor clerical matters), the Bidder must promptly notify the DBSA in writing of such discrepancy, ambiguity, error or inconsistency in order to afford the DBSA an opportunity to consider what corrective action is necessary (if any).
- 7.3 Any actual discrepancy, ambiguity, error or inconsistency in this RFP or any other information provided by the DBSA will, if possible, be corrected and provided to all Bidders without attribution to the Bidder who provided the written notice.

## **8. ADDITIONS AND AMENDMENTS TO THE RFP**

- 8.1 The DBSA reserves the right to change any information in, or to issue any addendum to this RFP before the Closing Time. The DBSA and its officers, employees and advisors will not be liable in connection with either the exercise of, or failure to exercise this right.
- 8.2 If the DBSA exercises its right to change information in terms of clause 8.1, it may seek amended Tenders from all Bidders.

## **9. REPRESENTATIONS**

No representations made by or on behalf of the DBSA in relation to this RFP will be binding on the DBSA unless that representation is expressly incorporated into the contract ultimately entered between the DBSA and the successful Bidder.

## **10. CONFIDENTIALITY**

- 10.1 All persons (including all Bidders) obtaining or receiving this RFP and any other information in connection with this RFP or the Tendering Process must keep the contents of the RFP and other such information confidential, and not disclose or use the information except as required for the purpose of developing a proposal in response to this RFP.

## **11. REQUESTS FOR CLARIFICATION OR FURTHER INFORMATION**

- 11.1 All communications relating to this RFP and the Tendering Process must be directed to the Tender Officer.
- 11.2 All questions or requests for further information or clarification of this RFP or any other document

issued in connection with the Tendering Process must be submitted to the Tender Officer in writing, and most preferably by e-mail to [tebogoSCM@dbsa.org](mailto:tebogoSCM@dbsa.org)

- 11.3 Any communication by a Bidder to the DBSA will be effective upon receipt by the Tender Officer (provided such communication is in the required format).
- 11.4 The DBSA has restricted the period during which it will accept questions or requests for further information or clarification and reserves the right not to respond to any enquiry or request, irrespective of when such enquiry or request is received.
- 11.5 Except where the DBSA is of the opinion that issues raised apply only to an individual Bidder, questions submitted and answers provided will be made available to all Bidders by e-mail, as well as on the DBSA's website without identifying the person or organisation which submitted the question.
- 11.6 In all other instances, the DBSA may directly provide any written notification or response to a Bidder by email to the address of the Bidder (as notified by the Bidder to the Tender Manager).
- 11.7 A Bidder may, by notifying the Tender Officer in writing, withdraw a question submitted in accordance with clause 12, in circumstances where the Bidder does not wish the DBSA to publish its response to the question to all Bidders.

## **12. UNAUTHORISED COMMUNICATIONS**

- 12.1 Communications (including promotional or advertising activities) with staff of the DBSA or their advisors assisting with the Tendering Process are not permitted during the Tendering Process, or otherwise with the prior consent of the Tender Officer. Nothing in this clause 12 is intended to prevent communications with staff of, or advisors to, the DBSA to the extent that such communications do not relate to this RFP or the Tendering Process.
- 12.2 Bidders must not otherwise engage in any activities that may be perceived as, or that may have the effect of, influencing the outcomes of the Tendering Process in any way.

## **13. IMPROPER ASSISTANCE, FRAUD AND CORRUPTION**

- 13.1 Bidders may not seek or obtain the assistance of employees of the DBSA in the preparation of their tender responses.
- 13.2 The DBSA may in its absolute discretion, immediately disqualify a Bidder that it believes has sought or obtained such improper assistance.
- 13.3 Bidders are to be familiar with the implications of contravening the Prevention and Combating of Corrupt Activities Act, 2004 and any other relevant legislation.

## **14. ANTI-COMPETITIVE CONDUCT**

- 14.1 Bidders and their respective officers, employees, agents and advisors must not engage in any collusion, anti-competitive conduct or any other similar conduct in respect of this Tendering

Process with any other Bidder or any other person(s) in relation to:

- 14.1.1 the preparation or lodgement of their Bid
- 14.1.2 the evaluation and clarification of their Bid; and
- 14.1.3 the conduct of negotiations with the DBSA.

14.2 For the purposes of this clause 14, collusion, anti-competitive conduct or any other similar conduct may include disclosure, exchange and clarification of information whether or not such information is confidential to the DBSA or any other Bidder or any other person or organisation.

14.3 In addition to any other remedies available to it under law or contract, the DBSA may, in its absolute discretion, immediately disqualify a Bidder that it believes has engaged in any collusive, anti-competitive conduct or any other similar conduct during or before the Tendering Process.

## **15. COMPLAINTS ABOUT THE TENDERING PROCESS**

15.1 Any complaint about the RFP or the Tendering Process must be submitted to the Supply Chain Management Unit in writing, by email, immediately upon the cause of the complaint arising or becoming known to the Bidder, ([tenders@dbsa.org](mailto:tenders@dbsa.org))

15.2 The written complaint must set out:

- 15.2.1 the basis for the complaint, specifying the issues involved;
- 15.2.2 how the subject of the complaint affects the organisation or person making the complaint;
- 15.2.3 any relevant background information; and
- 15.2.4 the outcome desired by the person or organisation making the complaint.

15.3 If the matter relates to the conduct of an employee of the DBSA, the complaint should be addressed in writing marked for the attention of the Chief Executive Officer of the DBSA, and delivered to the physical address of the DBSA, as notified.

## **16. CONFLICT OF INTEREST**

16.1 A Bidder must not, and must ensure that its officers, employees, agents and advisors do not place themselves in a position that may give rise to actual, potential or perceived conflict of interest between the interests of the DBSA and the Bidder's interests during the Tender Process.

16.2 The Bidder is required to provide details of any interests, relationships or clients which may or do give rise to a conflict of interest in relation to the supply of the services under any contract that may result from this RFP. If the Bidder submits its Bid and a subsequent conflict of interest arises, or is likely to arise, which was not disclosed in the Bid, the Bidder must notify the DBSA immediately in writing of that conflict.

16.3 The DBSA may immediately disqualify a Bidder from the Tendering Process if the Bidder fails to notify the DBSA of the conflict as required.

## **17. LATE BIDS**

- 17.1 Bids must be delivered by the Closing Time. The Closing Time may be extended by the DBSA in its absolute discretion by providing written notice to Bidders.
- 17.2 Bids delivered after the Closing Time or lodged at a location or in a manner that is contrary to that specified in this RFP will be disqualified from the Tendering Process and will be ineligible for consideration. However, a late Bid may be accepted where the Bidder can clearly demonstrate (to the satisfaction of the DBSA, in its sole discretion) that late lodgement of the Bid was caused by the DBSA; that access was denied or hindered in relation to the physical tender box; or that a major/critical incident hindered the delivery of the Bid and, in all cases, that the integrity of the Tendering Process will not be compromised by accepting a Bid after the Closing Time.
- 17.3 The determination of the DBSA as to the actual time that a Bid is lodged is final. Subject to clause 17.2, all Bids lodged after the Closing Time will be recorded by the DBSA and will only be opened for the purposes of identifying a business name and address of the Bidder. The DBSA will inform a Bidder whose Bid was lodged after the Closing Time of its ineligibility for consideration. The general operating practice is for the late Bid to be returned within 5 (five) working days of receipt or within 5 (five) working days after determination not to accept a late Bid.

## **18. BIDDER'S RESPONSIBILITIES**

- 18.1 Bidders are responsible for:
- 18.1.1 examining this RFP and any documents referenced or attached to this RFP and any other information made or to be made available by the DBSA to Bidders in connection with this RFP;
  - 18.1.2 fully informing themselves in relation to all matters arising from this RFP, including all matters regarding the DBSA's requirements for the provision of the Services;
  - 18.1.3 ensuring that their Bids are accurate and complete;
  - 18.1.4 making their own enquiries and assessing all risks regarding this RFP, and fully considering and incorporating the impact of any known and unknown risks into their Bid;
  - 18.1.5 ensuring that they comply with all applicable laws in regard to the Tendering Process particularly as specified by National Treasury Regulations, Guidelines, Instruction Notes and Practice Notes and other relevant legislation as published from time to time in the Government Gazette; and
  - 18.1.6 submitting all Compulsory Documents.

- 18.2 South African bidders with annual total revenue of ZAR10 million or less qualify as Exempted Micro Enterprises (EMEs) in terms of the B-BBEE Act must submit a certificate issued by a registered, independent auditor (who or which is not the Bidder or a part of the Bidder) or an accredited verification agency.
- 18.3 South African bidders other than EMEs must submit their original and valid B-BBEE status level verification certificate or a certified copy, or a sworn affidavit thereof, substantiating their B-BBEE status. The submission of such certificates must comply with the requirements of instructions and guidelines issued by National Treasury and be in accordance with the applicable notices published by the Department of Trade and Industry in the Government Gazette.
- 18.4 The DBSA reserves the right to require of a Bidder, either before a Bid is adjudicated or at any time subsequently, to substantiate any claim in regard to preferences, in any manner required by the DBSA.
- 18.5 Failure to provide the required information may result in disqualification of the Bidder.

## **19. PREPARATION OF BIDS**

- 19.1 Bidders must ensure that:
- 19.1.1 their Bid is submitted in the required format as stipulated in this RFP; and
  - 19.1.2 all the required information fields in the Bid are completed in full and contain the information requested by the DBSA.
- 19.2 The DBSA may in its absolute discretion reject a Bid that does not include the information requested or is not in the format required.
- 19.3 Unnecessarily elaborate responses or other representations beyond that which is sufficient to present a complete and effective tender proposal are not desired or required. Elaborate and expensive visual and other presentation aids are not necessary.
- 19.4 Where the Bidder is unwilling to accept a specified condition, the non-acceptance must be clearly and expressly stated. Prominence must be given to the statement detailing the non-acceptance. It is not sufficient that the statement appears only as part of an attachment to the Bid or be included in a general statement of the Bidders usual operating conditions.
- 19.5 An incomplete Bid may be disqualified or assessed solely on the information completed or received with the Bid.

## **20. ILLEGIBLE CONTENT, ALTERATION AND ERASURES**

- 20.1 Incomplete Bids may be disqualified or evaluated solely on information contained in the Bid.
- 20.2 The DBSA may disregard any content in a Tender that is illegible and will be under no obligation whatsoever to seek clarification from the Bidder.
- 20.3 The DBSA may permit a Bidder to correct an unintentional error in its Bid where that error becomes known or apparent after the Closing Time, but in no event will any correction be



permitted if the DBSA reasonably considers that the correction would materially alter the substance of the Bid or effect the fairness of the Tendering Process.

## **21. OBLIGATION TO NOTIFY ERRORS**

If, after a Bidder's Response has been submitted, the Bidder becomes aware of an error in the Bidders Response (including an error in pricing but excluding clerical errors which would have no bearing on the evaluation of the Bid), the Bidder must promptly notify the DBSA of such error.

## **22. RESPONSIBILITY FOR BIDDING COSTS**

22.1 The Bidders participation or involvement in any stage of the Tendering Process is at the Bidders sole risk, cost and expense. The DBSA will not be held responsible for, or pay for, any expense or loss that may be incurred by Bidders in relation to the preparation or lodgement of their Bid.

22.2 The DBSA is not liable to the Bidder for any costs on the basis of any contractual, promissory or restitutionary grounds whatsoever as a consequence of any matter relating to the Bidders participation in the Tendering Process, including without limitation, instances where:

22.2.1 the Bidder is not engaged to perform under any contract; or

22.2.2 the DBSA exercises any right under this RFP or at law.

## **23. DISCLOSURE OF BID CONTENTS AND BID INFORMATION**

23.1 All Bids received by the DBSA will be treated as confidential. The DBSA will not disclose contents of any Bid and Bid information, except:

23.1.1 as required by law;

23.1.2 for the purpose of investigations by other government authorities having relevant jurisdiction;

23.1.3 to external consultants and advisors of the DBSA engaged to assist with the Tendering Process; or for the general information of Bidders required to be disclosed as per National Treasury Regulations, Guidelines, Instruction Notes or Practice Notes.

## **24. USE OF BIDS**

24.1 Upon submission in accordance with the requirements relating to the submission of Bids, all Bids submitted become the property of the DBSA. Bidders will retain all ownership rights in any intellectual property contained in the Bids.

24.2 Each Bidder, by submission of their Bid, is deemed to have licensed the DBSA to reproduce the whole, or any portion, of their Bid for the sole purposes of enabling the DBSA to evaluate the Bid.

## 25. BID ACCEPTANCE

All Bids received must remain open for acceptance for a minimum period of 90 (Ninety) days from the Closing Time. This period may be extended by written mutual agreement between the DBSA and the Bidder.

## 26. EVALUATION PROCESS

26.1 The Bids will be evaluated and adjudicated as follows:

### 26.1.1 First Stage – Test for administrative Responsiveness

The test for administrative responsiveness will include the following:

#### **Stage 1: Responsiveness**

The Tenderer should be able to provide all the relevant information required in the Supplier Information Form (SIF) which will include but not limited to;

**A. Tenderers who do not adhere to those criteria listed a PRE-QUALIFIER, will be disqualified immediately.**

Responsiveness Criteria		Prequalifying Criteria	Applicable to this Tender (Y/N)
1	Adherence in submitting Tender as two stage folders Folder 1 – Prequalifying and Functionality proposal Folder 2 – Pricing proposal	Pre-Qualifier	Y
2	Attendance Register of the Compulsory Briefing Session attended by the Tenderer.	Pre-Qualifier	Y
3	Proof of Registration with a recognized professional body/ institution, relevant to tender requirement (To be determined in line with Tender Requirement)	Pre-Qualifier	Y
4	Provide proof of compensation liability cover (COIDA).	Pre-Qualifier	Y

**B. Tenderers who do not adhere to the indicated response time for clarifications requested by the Employer will be deemed to be non-responsive and their submissions will not be evaluated further.**

**C.**

Responsiveness Criteria		Clarification Time	Applicable to this Tender (Y/N)
1	Standard conditions of tender as required.	48 hours	Y
2	Returnable documents completed and signed.	48 hours	Y
3	Submission of Proof of Registration with National Treasury Central Supplier Database (CSD) Summary Report or A Valid and Active Tax Compliance Status Pin issued by SARS for Tax Compliance Status Verification: N.B - Bidder must be fully registered & tax compliant to do business with the DBSA.	48 hours	Y
4	A valid and active Tax Compliance Status Pin issued by SARS.	48 hours	Y
5	Valid original/ certified letter of good standing (COIDA).	48 hours	Y

Only those Bidders which satisfy all the Pre-Qualifying Criteria of the First Stage will be eligible to participate in the Tendering Process further. Bids which do not satisfy all the Pre-Qualifying Criteria of the First Stage will not be evaluated further.

**26.1.2 Second Stage – Functional criteria**

26.1.1 Only those Bidders which score **[70]** points or higher (out of a possible 100) during the functional evaluation of the Second Stage will be evaluated further. Bidders are required to submit supporting documentation evidencing their compliance with each requirement, where applicable.

26.1.2 Only bidders that scored the minimum threshold of 70 Points on the Second Stage of Evaluation (Client Satisfaction) will be evaluated for the Third Stage (Brand Health/ Perception Survey).

Bidders will be assessed on the functional criteria (Second Stage and Third Stage) as set out in this RFP. Only those Bidders which comply with the eligibility criteria will proceed to the Fourth Stage.

**26.1.3 Fourth Stage – Price**

26.1.3.1 Those Bidders which have passed the First Stage (Responsiveness Test) and Second Stage (Functional Evaluation) of the tender process will be eligible to be evaluated on the Third Stage, based on price, in accordance with the PPPFA regulations.

26.1.3.2 The recommended preferred Bidder will be the Bidder with the lowest overall price in the Third Stage of the Bid evaluation, unless the DBSA exercises its right to cancel the RFP, in line with the PPPFA Regulations.

**26.2 NB: Bidders are required to submit, as Annexure J to their Bids, any documentation which supports the responses provided in respect of the Eligibility Criteria below.**

**26.3 First Stage: Pre-Qualifying Criteria**

Only those Bidders which satisfy all the Pre-Qualifying Criteria will be eligible to participate in the Tendering Process further. Bids which do not satisfy all the Pre-Qualifying Criteria will not be evaluated further. Please refer to the table above

**Note: A tender that fails to meet any Pre-Qualifying Criteria stipulated herein in the tender documents is an unacceptable tender. Please refer to the table above**

**26.4 Second Stage: Functional Criteria (Client Satisfaction)**

The technical proposal will be evaluated according to the following criteria and scoring system. The technical score will be calculated out of 100 points, and only those bids that achieve a threshold of **70** points for the technical proposal will move to the next level of evaluation where a score for price and BBEE.

Proposals received for the **REPLACEMENT OF TWO UPS UNIT AND BATTERIES** will be evaluated against the criteria set out below:

Sub-Criteria	Description	Weightings
<p><b>Company must have five or more years' experience in installation and commissioning of UPS systems.</b></p>	<ul style="list-style-type: none"> <li>• Provide a detailed company profile indicating experience in the following services. Supply and Installation of UPS systems completed within the last five years.</li> <li>• Please Note: A profile must indicate a list of five or more projects in relation to UPS systems in the last five years.</li> <li>• Experience: 5 or more projects = 15 points 3 to 4 projects =10 points 1 to 2 projects= 5 points</li> </ul>	<p><b>15</b></p>

Sub-Criteria	Description	Weightings
	<ul style="list-style-type: none"> <li>• Provide Four (4) signed and dated relevant contactable reference letters indicating work carried out or completed successfully in supply, installation and commissioning of UPS systems including data center(s) UPS within the last five years.</li> <li>• <b>Please Note:</b> Required reference letters must be on the relevant company letterhead, indicating, project amount duration of work and completion certificate. References provided in a list format and purchase order will not be recommended.</li> </ul> <p>4 or more references = 20 points  3 references = 15 points  2 references = 10 points  1 reference = 5 points</p>	<b>20</b>
<b>Qualifications, experience, and Capacity</b>	Provide a fully detailed CV, supported by certified qualification certificate of the following required site personnel indicating duties, skills performed, related current employer, previous employer and years of work experience in electrical heavy current filed.	
<b>Handyman CV accompanied by certified copies of Identity document: No. of years' experience: at least 5 years in build environment</b>	<p><b>Handyman:</b></p> <ul style="list-style-type: none"> <li>• Handyman with 5 years or more experience = 15 points</li> <li>• Handyman with 3 to 4 years' experience = 10 points</li> <li>• Handyman with 2 years' experience = 5 points</li> <li>• Handyman with 1 years' experience = 0</li> </ul>	<b>15</b>
<b>Trade tested Electrical Artisan with 3phase wireman's license recognized by the department of labor: Number of years of experience 5 years or more.</b>	<p><b>Qualified Trade Test Artisan/ Technician with 3 Phase installation license.</b></p> <ul style="list-style-type: none"> <li>• Electrical Artisan/ technician with 5 or more years' experience = 20 points</li> <li>• Electrical Artisan/ Technician with 3 to 4 years' experience = 15 points</li> <li>• Electrical Artisan/ Technician with 2 years' experience = 10 points</li> <li>• Electrical Artisan/ Technician with 1 years' experience =5 points</li> </ul>	<b>20</b>

Sub-Criteria	Description	Weightings
<b>Site agent with Electrical Artisan certificate, minimum N3 certificate and wireman license</b>  <b>No. of years' experience: minimum 5 years in the relevant field</b>	<b>Qualified Site agent with 5 years build in environment experience.</b> <ul style="list-style-type: none"> <li>• Site agent with 5 years' experience or more = 20 points</li> <li>• Site agent with 3-4 years' experience = 15 points</li> <li>• Site agent with 2 years' experience = 10 points</li> <li>• Site agent with 1 years' experience = 5 points</li> </ul>	<b>20</b>
<b>Project Plan and timelines</b>	<ul style="list-style-type: none"> <li>• Provide a detailed project plan and timelines = 10 points</li> <li>• No detailed project plan = 0 points</li> </ul>	<b>10</b>
<b>Total</b>		<b>100</b>

**NB: Bidders scoring less than 70% on functionality will not be further evaluated.**

## 26.5 Third Stage: Price

26.5.1 The Third Stage of evaluation of the Bids will be in respect of price and specific goals.

## 27. Risk Analysis and Objective Criteria

**(This must only be included in the tender document if it is applicable, ensure that the list is specific as to what your objective criteria are)**

The DBSA reserves the right to award the tender to the tenderer who scores the highest number of points overall in line with Section (2) (1) (f) of the PPPFA, unless there are **objective criteria** which will justify the award of the tender to another tenderer. The objective criteria that the DBSA may apply in this bid process includes:

- i. Any bidder that has a **cumulative order book totaling three (3) Awards with outstanding value**, will be excluded from the selection.
- ii. Where a bidder has three (3) active Awards with an outstanding value and the outstanding value is 10% or less, indicating the project is nearing completion, the bidder may be included in the selection.

- iii. Where a bidder has three (3) active Awards with an outstanding value and at least one of the projects has stalled for a period of six (6) months or more, or the client has placed the project on hold indefinitely, the bidder may be included in the selection.
- iv. The DBSA has the discretion to apply an objective criterion.

## 28. Due Diligence

DBSA shall perform a due diligence exercise on the preferred bidder to determine its risk profile. The due diligence exercise may take the following factors into account inter alia.

### a. Judgements and criminal convictions

DBSA may consider previous civil judgements against the preferred bidder as part of its risk assessment. DBSA may also consider whether the preferred bidder or any of its directors have been convicted of a serious offence.

### b. Pending litigation/liquidation/business rescue (distinct from Working Capital)

DBSA may consider any pending litigation in a court of law or administrative tribunal as part of its risk assessment.

### c. Performance

DBSA will not consider the Service provider having a history of poor performance on any task orders/purchase orders or contracts, including poor performance in respect of compliance with policies or procedures regarding safety, health, quality control or environment, or having committed a serious and gross breach of contract.

### d. Reputational harm

If DBSA is likely to suffer substantial reputational harm because of doing business with the preferred service provider, it may take this into account as part of its risk assessment.

### e. Restricted/Blacklisted

Is not under restrictions, or has principals who are under restrictions, preventing participating in the employer's procurement.

### f. Vetting

The DBSA reserves the right to conduct vetting on the tenderer or any of its directors.

### g. PEP Checks for both Companies and Individual directors, as well as Procure Check and or any other systems that the DBSA may choose to utilize (which may be conducted by an authorized third party) that would be done to assess all risks, including but not limited to

- a. Financial stability of the bidder based on key ratio analysis ;
- b. Efficiency ;
- c. Profitability ;
- d. Financial Risk;
- e. Liquidity ;
- f. Acid Test ;
- g. Solvency; and
- h. Commercial relationship with a politically exposed and brand risk

- v. The DBSA reserves the right to award the scope in full or part thereof, subject to budget availability.
- vi. The DBSA reserves the right to negotiate to ensure the value for money principle is not compromised.

**29.** Generally, suppliers have their own business standards and regulations. Although DBSA cannot control the actions of our suppliers, we will not tolerate any Illegal activities. These include, but are not limited to:

- Misrepresentation of any kind (e.g. origin of manufacture, specifications, intellectual property rights, etc);
- Collusion;
- Failure to disclose accurate information required during the sourcing activity (ownership, financial situation, BBBEE status, etc.);
- Corrupt activities listed above; and
- Harassment, intimidation or other aggressive actions towards DBSA's employees.

### **30. STATUS OF BID**

- 30.1 Each Bid constitutes an irrevocable offer by the Bidder to the DBSA to provide the Services required and otherwise to satisfy the requirements of the Specification as set out in this RFP.
- 30.2 A Bid must not be conditional on:
- 30.2.1 the Board approval of the Bidder or any related governing body of the Bidder being obtained.
  - 30.2.2 the Bidder conducting due diligence or any other form of enquiry or investigation.
  - 30.2.3 the Bidder (or any other party) obtaining any regulatory approval or consent.
  - 30.2.4 the Bidder obtaining the consent or approval of any third party; or
  - 30.2.5 the Bidder stating that it wishes to discuss or negotiate any commercial terms of the contract.
- 30.3 The DBSA may, in its absolute discretion, disregard any Bid that is, or is stated to be, subject to any one or more of the conditions detailed above (or any other relevant conditions).
- 30.4 The DBSA reserves the right to accept a Bid in part or in whole or to negotiate with a Bidder in accordance with the provisions of this RFP and the applicable laws and regulations.

### **31. CLARIFICATION OF BIDS**

- 31.1 The DBSA may seek clarification from and enter into discussions with any or all of the Bidders in relation to their Bid. The DBSA may use the information obtained when clarification is sought or discussions are held in interpreting the Bid and evaluating the cost and risk of accepting the Bid. Failure to supply clarification to the satisfaction of the DBSA may render the Bid liable to disqualification.
- 31.2 The DBSA is under no obligation to seek clarification of anything in a Bid and reserves the right to disregard any clarification that the DBSA considers to be unsolicited or otherwise impermissible or irrelevant in accordance with the rules set out in this RFP.

### **32. DISCUSSION WITH BIDDERS**

- 32.1 The DBSA may elect to engage in detailed discussions with any one or more Bidder(s), with a view to maximising the benefits of this RFP as measured against the evaluation criteria and in fully understanding a Bidder's offer.



- 32.2 Where applicable, the DBSA will invite Bidders to give a presentation to the DBSA in relation to their submissions.
- 32.3 The DBSA is under no obligation to undertake discussions with, and Bidders.
- 32.4 In addition to presentations and discussions, the DBSA may request some or all Bidders to:
- 32.4.1 conduct a site visit, if applicable;
  - 32.4.2 provide references or additional information; and/or
  - 32.4.3 make themselves available for panel interviews.

### **33. SUCCESSFUL BIDS**

- 33.1 Selection as a successful Bidder does not give rise to a contract (express or implied) between the successful Bidder and the DBSA for the supply of the Services. No legal relationship will exist between the DBSA and a successful Bidder for the supply of the Services until such time as a binding contract is executed by them.
- 33.2 The DBSA may, in its absolute discretion, decide not to enter into pre-contractual negotiations with a successful Bidder.
- 33.3 A Bidder is bound by its Bid and all other documents forming part of the Bidder's Response and, if selected as a successful Bidder, must enter into a contract on the basis of the Bid with or without further negotiation.

### **34. NO OBLIGATION TO ENTER INTO CONTRACT**

- 34.1 The DBSA is under no obligation to appoint a successful Bidder or Bidders (as the case may be), or to enter into a contract with a successful Bidder or any other person, if it is unable to identify a Bid that complies in all relevant respects with the requirements of the DBSA, or if due to changed circumstances, there is no longer a need for the Services requested, or if funds are no longer available to cover the total envisaged expenditure. For the avoidance of any doubt, in these circumstances the DBSA will be free to proceed via any alternative process.
- 34.2 The DBSA may conduct a debriefing session for all Bidders (successful and unsuccessful). Attendance at such debriefing session is optional.

### **35. BIDDER WARRANTIES**

- 35.1 By submitting a Bid, a Bidder warrants that:
- 35.1.1 it did not rely on any express or implied statement, warranty or representation, whether oral, written, or otherwise made by or on behalf of the DBSA, its officers, employees, or advisers other than any statement, warranty or representation expressly contained in the RFP;

- 35.1.2 it did not use the improper assistance of DBSA's employees or information unlawfully obtained from them in compiling its Bid;
- 35.1.3 it is responsible for all costs and expenses related to the preparation and lodgement of its Bid, any subsequent negotiation, and any future process connected with or relating to the Tendering Process;
- 35.1.4 it accepts and will comply with the terms set out in this RFP; and
- 35.1.5 it will provide additional information in a timely manner as requested by the DBSA to clarify any matters contained in the Bid.

### **36. DBSA'S RIGHTS**

- 36.1 Notwithstanding anything else in this RFP, and without limiting its rights at law or otherwise, the DBSA reserves the right, in its absolute discretion at any time, to:
  - 36.1.1 cease to proceed with, or suspend the Tendering Process prior to the execution of a formal written contract;
  - 36.1.2 alter the structure and/or the timing of this RFP or the Tendering Process;
  - 36.1.3 vary or extend any time or date specified in this RFP
  - 36.1.4 terminate the participation of any Bidder or any other person in the Tendering Process;
  - 36.1.5 require additional information or clarification from any Bidder or any other person;
  - 36.1.6 provide additional information or clarification;
  - 36.1.7 negotiate with any one or more Bidder;
  - 36.1.8 call for new Bid;
  - 36.1.9 reject any Bid received after the Closing Time; or
  - 36.1.10 reject any Bid that does not comply with the requirements of this RFP.

### **37. GOVERNING LAWS**

- 37.1 This RFP and the Tendering Process are governed by the laws of the Republic of South Africa.
- 37.2 Each Bidder must comply with all relevant laws in preparing and lodging its Bid and in taking part in the Tendering Process.
- 37.3 All Bids must be completed using the English language and all costing must be in South African Rand (ZAR).

# Development Bank of Southern Africa

## Terms of Reference

### Replacement of Two UPS Units and Batteries

#### 1. Background

In keeping with the DBSA facility management agenda and provision of world class facilities services, the DBSA seeks to replace two UPS units and batteries and bypass panel on a once off installation to an external party that will ensure that the units are installed according to the manufacture's specification.

#### 2. System specification.

- Carry out a complete replacement of existing main building electrical infrastructure UPS units. And UPS 3M bypass panel

#### UPS 3M E3LUPS300KHS: Easy UPS 3L 300 kVA 400 V, Start-up 5x8

##### Status LEDs

LED	State	Description
ALARM	Steady or flashing red	Critical alarm
	Steady or flashing yellow	Warning alarm
	Off	No alarm condition
BYPASS	Steady yellow	The load is supplied by the bypass source
	Flashing yellow	There is an alarm condition on the bypass source
	Off	The load is not supplied by the bypass source
BATTERY	Steady yellow	The load is supplied by the battery source
	Flashing yellow	The battery source is unavailable
	Off	The load is not supplied by the battery source
INVERTER	Steady green	Inverter on
	Off	Inverter off

## Overview of 1+1 Redundant Parallel System with two different Battery Banks

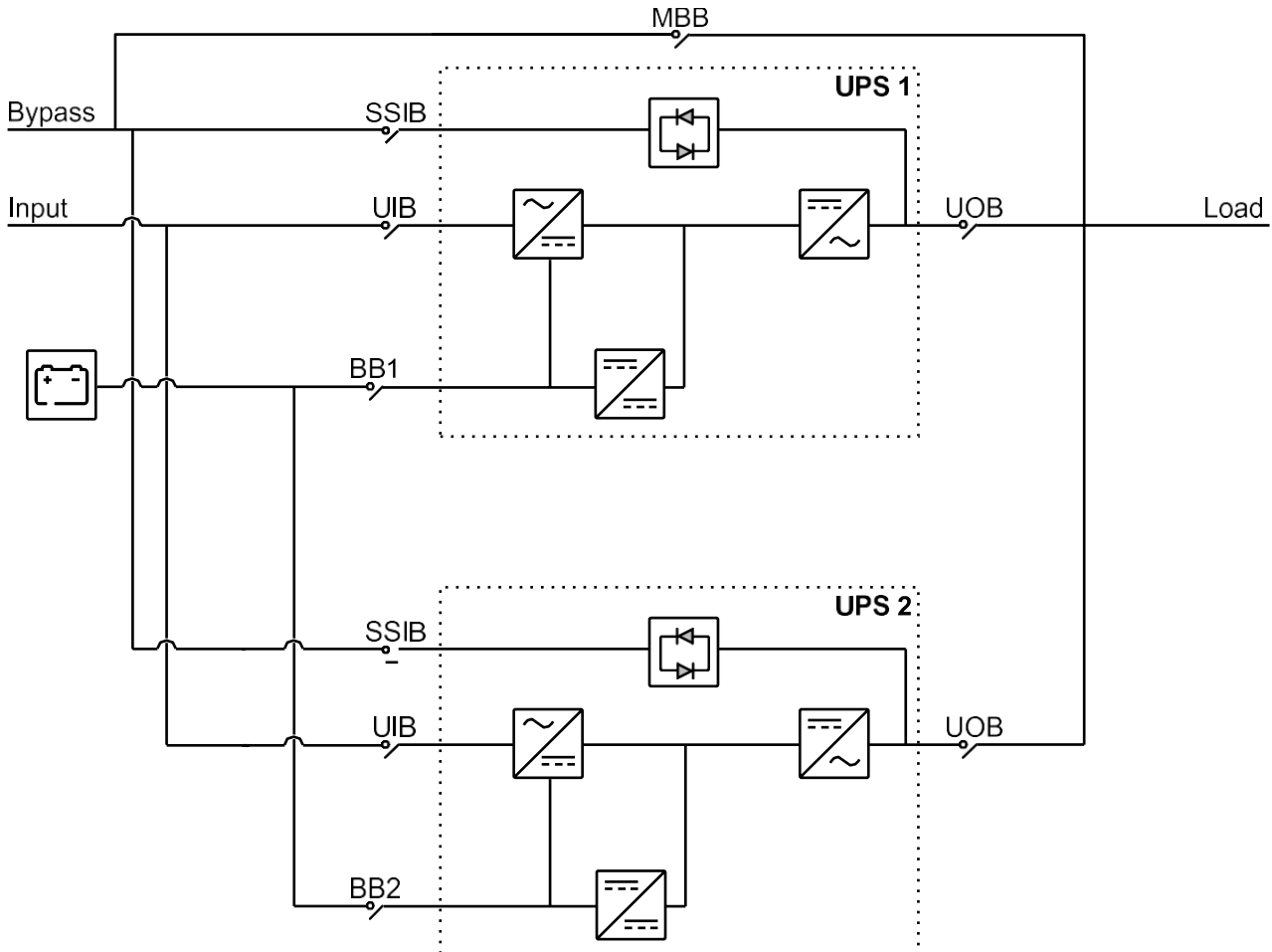

UIB	Unit input breaker
SSIB	Static switch input breaker
UOB	Unit output breaker
MBB	Maintenance bypass breaker
BB1	Battery breaker 1
BB2	Battery breaker 2

### Input Power Factor

The values are at a 400 V 50 Hz linear load.

<b>UPS rating</b>	<b>300 kVA</b>
25% load	0.99

50% load	0.99
75% load	0.99
100% load	0.99

### Efficiency

The values are at a 400 V 50 Hz linear load at output power factor 1.

#### Normal Mode

UPS rating	300 kVA
25% load	95.13%
50% load	95.54%
75% load	95.17%
100% load	94.56%

#### ECO mode

UPS rating	300 kVA
25% load	99.07%
50% load	98.99%
75% load	99.03%
100% load	99.05%

#### Battery operation

UPS rating	300 kVA
25% load	94.37%
50% load	95.03%
75% load	94.75%
100% load	94.19%

### Derating Due to Load Power Factor

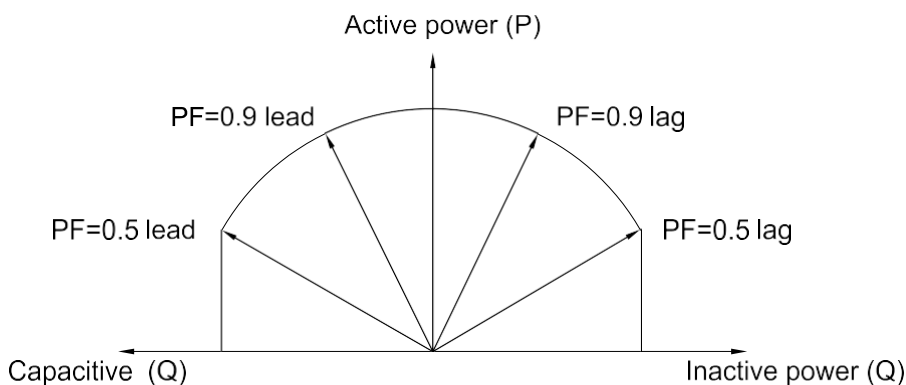

### End of Discharge Voltage

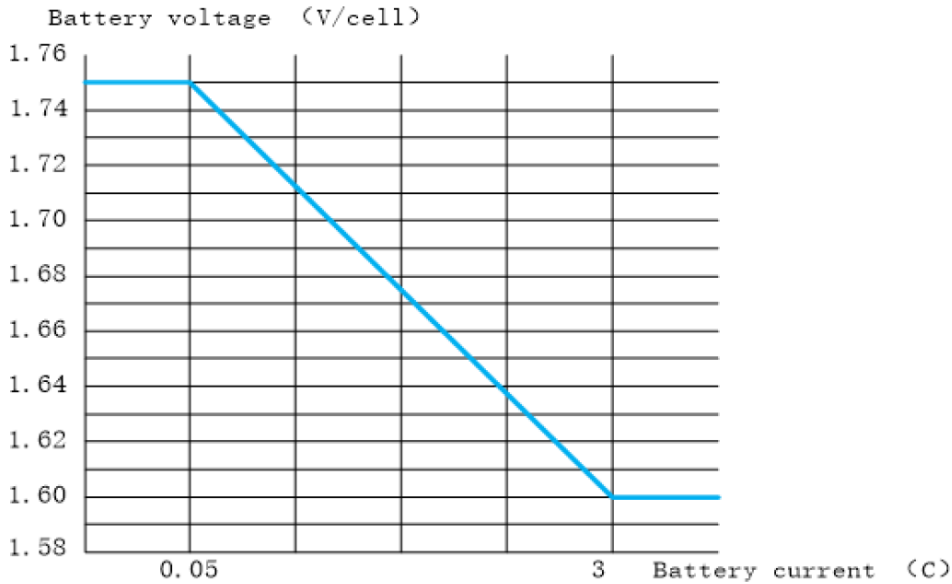

### Battery Runtimes

UPS rating	300 kVA			
Power factor	25% load	50% load	75% load	100% load
E3MCBC10B				
E3MCBC10C				
E3MCBC10D	29	11.5	6.1	
E3MCBC10E	41.5	16	8.3	
2 x E3MCBC7D	20.5	8		
2 x E3MCBC10A	28.5	11	5.9	
2 x E3MCBC10B	41.5	16	8.3	
2 x E3MCBC10C	47.5	19	10	5.6
2 x E3MCBC10D	67.5	29.5	17.5	11.5
2 x E3MCBC10E	97	42	24.5	16
3 x E3MCBC7C	21	8		
3 x E3MCBC7D	34.5	14	8	
3 x E3MCBC10A	47	20	11	7.2
3 x E3MCBC10B	68.5	28.5	16	10
3 x E3MCBC10C	78	33	19	12
3 x E3MCBC10D	105	48.5	29.5	20
3 x E3MCBC10E	155	69.5	41.5	28.5

## Communication and Management

- User interface with status LEDs and display
- RS485
- SNMP (options)
- Dry contacts
- USB

## Facility Planning for 300 kVA UPSs for External Batteries

### Input Specifications

<b>UPS rating</b>	<b>300 kVA</b>			
<b>Voltage (V)</b>	<b>380</b>	<b>400</b>	<b>415</b>	
Connections	L1, L2, L3, N, PE			
Input voltage range (V)	323-477 (full load)			
Frequency range (Hz)	40-70			
Nominal input current (A)	485	461	444	
Maximum input current (A)	568	540	520	
Input current limitation (A)	720			
Total harmonic distortion (THDI)	<3% for linear loads <5% for non-linear loads			
Input power factor	>0.99			
Maximum short circuit rating	I <sub>cc</sub> =35 kA			
Ramp-in	7 seconds			

### Bypass Specifications

<b>UPS rating</b>	<b>300 kVA</b>		
<b>Voltage (V)</b>	<b>380</b>	<b>400</b>	<b>415</b>
Connections	L1, L2, L3, N, PE		
Overload capacity	≤115% continuous 125% for 10 minutes 150% for 1 minute		
Minimum bypass voltage (V)	209	221	228
Maximum bypass voltage (V)	475	480	477
Frequency (Hz)	50 or 60		
Frequency range (%)	±1, ±2, ±4, ±5, ±10. Default is ±10 (user selectable).		
Nominal bypass current (A)	460	437	422
Maximum short circuit rating	Icc=35 kA		

### Battery Specifications

<b>UPS rating</b>	<b>300 kVA</b>		
<b>Voltage (V)</b>	<b>380</b>	<b>400</b>	<b>415</b>
Connections	L1, L2, L3, N, PE		
Overload capacity <sup>1</sup>	105% continuous 125% for 10 minutes 150% for 1 minute		
Output voltage regulation	±1%		
Dynamic load response	20 milliseconds		
Output power factor	1		
Nominal output current (A)	456	433	417
Total harmonic distortion (THDU)	<2% at 100% linear load <4% at 100% non-linear load		
Output frequency (Hz)	50 or 60		



Slew rate (Hz/sec)	Programmable: 0.5 to 2.0 Default is 0.5	
Output performance classification (according to IEC/ EN62040-3)	VFI-SS-111	
Load power factor	0.5 leading to 0.5 lagging without derating	
Output short circuit current (inverter)	820 A/200 ms	

### 300 kVA UPS

	Cable size per phase (mm <sup>2</sup> )	Neutral cable size (mm <sup>2</sup> )	PE cable size (mm <sup>2</sup> )
Input	2 x 150	2 x 150	150
Bypass	2 x 150	2 x 150	150
Output	2 x 150	2 x 150	150
Battery	2 x 240	2 x 240	240

### Recommended Upstream Protection

NOTE: For local directives which require 4-pole circuit breakers: If neutral conductor is expected to carry a high current, due to line-neutral non-linear load, the circuit breaker must be rated according to expected neutral current.

UPS rating	300 kVA	
	Input	Bypass
Breaker type	NS630bN Mic 2.0 (33463/ NS33463)	NS630bN Mic 2.0 (33463/ NS33463)
In setting	1	1
Ir setting	0.9	0.9
Im setting	Isd=1.5-10	Isd=1.5-10

### Environmental

	Operating	Storage
Temperature	0 °C to 30 °C	-15 °C to 40 °C for systems with batteries -25 °C to 55 °C for systems without batteries
Relative humidity	0-95% non-condensing	
Elevation derating according to IEC 62040-3	Power derating factor: 0-1500 m: 1.000 1500-2000 m: 0.975	< 15000 m above sea level (or in an environment with equivalent air pressure)
Audible noise	<70 dBA at 100% load according to ISO3746	
Protection class	IP20 (air filter as standard)	
Color	RAL 9003	

**Heat Dissipation**

<b>UPS rating</b>	<b>300 kVA</b>	
	<b>W</b>	<b>BTU/hr</b>
Normal mode	17400	59386
Battery mode	16800	57338
ECO mode	2400	8191

**E3MUPS100KHSEasy UPS 3M 100kVA 400V 3:3 UPS for external batteries, Start-up5x8**

<b>MAIN</b>	
<b>Main Input Voltage</b>	400 V 3 phases
<b>Other Input Voltage</b>	380 V 415 V
<b>Main Output Voltage</b>	380 V / 415 V
<b>Other Output Voltage</b>	380 V / 415 V
<b>Rated power in W</b>	100 kW
<b>Rated power in VA</b>	100 kVA
<b>Provided equipment</b>	Dust filter Installation guide Start-up service
<b>PHYSICAL</b>	
<b>Colour</b>	White (RAL 9003)
<b>Height</b>	91.5 cm
<b>Width</b>	36 cm
<b>Depth</b>	85 cm
<b>Net weight</b>	145 kg
<b>USB compatible</b>	Yes
<b>INPUT</b>	
<b>Maximum input current</b>	177 A

<b>Max short time withstand current</b>	10 kA
<b>Input harmonic distortion</b>	Less than 3 % for full load
<b>Load power factor</b>	0.5 leading to 0.5 lagging
<b>Input Power Factor at Full Load</b>	0.99
<b>Input voltage limits</b>	342...477 V
<b>Number of input connectors</b>	1 hard wire 5-wire (3P + N + E)
<b>Network frequency</b>	40...70 Hz
<b>OUTPUT</b>	
<b>Maximum configurable power in VA</b>	100 kVA
<b>Maximum configurable power in W</b>	100 kW
<b>Output frequency</b>	50 Hz sync to mains    60 Hz sync to mains
<b>Harmonic distortion</b>	Less than 3 %
<b>Output harmonic distortion</b>	< 3% linear load and < 5% non-linear load
<b>Output overload operation</b>	10 minutes at 125% and 60 seconds at 150%
<b>UPS type</b>	Double conversion online
<b>Wave type</b>	Sine wave
<b>Bypass type</b>	Built-in static bypass
<b>Crest factor</b>	3 : 1
<b>ENVIRONMENT</b>	
<b>Ambient air temperature for operation</b>	0...40 °C

<b>Relative humidity</b>	0...95 % non-condensing
<b>Operating altitude</b>	0...4921 ft
<b>Ambient air temperature for storage</b>	-25...55 °C
<b>Storage Relative Humidity</b>	0...95 % non-condensing
<b>Storage altitude</b>	0.00...15240.00 m
<b>Acoustic level</b>	65 dBA
<b>Heat dissipation</b>	18767 Btu/h
<b>IP degree of protection</b>	IP20
<b>BATTERIES &amp; RUNTIME</b>	
<b>Battery type</b>	External battery system
<b>Number of battery filled slots</b>	0
<b>Number of battery free slots</b>	0
<b>COMMUNICATIONS &amp; MANAGEMENT</b>	
<b>Free slots</b>	1
<b>Control panel</b>	Touch screen LCD user interface
<b>PACKING UNITS</b>	
<b>Unit Type of Package 1</b>	PCE
<b>Number of Units in Package 1</b>	1
<b>Package 1 Height</b>	114 cm
<b>Package 1 Width</b>	96.5 cm
<b>Package 1 Length</b>	47.5 cm
<b>Package 1 Weight</b>	169 kg
<b>OFFER SUSTANABILITY</b>	

<b>Sustainable offer status</b>	Green Premium product
<b>REACH Regulation</b>	REACH Declaration
<b>Mercury free</b>	Yes
<b>Warranty</b>	1 year on-site repair or replace with factory authorized Start-Up

### 3. Cabling

commission the existing DB the main server room and replace it with SU4 flush type for new wiring.  
 35mm by 40m flexi core (4C+E)  
 35mm by 90m flexi core (4C+E)  
 95mm tails by 1000m  
 Replace all main existing batteries

Supply and install additional batteries for 80 KVA unit at Vulindlela building

32 of 1150K 12V.  
 AMP.HR (20HR) 105.  
 RESERVE CAPACITY 180.  
 COLD CRANKING AMPS (-18dgC) 625.  
 One battery cabinet.

### 4. Work requirement

- The contractor shall not conduct any works that is beyond the TOR.
- The contractor shall provide construction personnel, equipment, material, tools and supervision as needed to complete the services that meets the technical requirements in this statement of work as per Tor.
- The contractor shall identify a site agent or supervisor who shall be responsible for the overall management of the project and shall represent the contractor on site during work as per Tor.
- Demarcation and housekeeping play a major role in maintaining DBSA safety standards and it should be noted that the contractor is responsible for site demarcation, keeping a clean and tidy site and the daily removal of rubble, redundant equipment to the appropriate designated area within the DBSA campus and debris, etc. (to be discussed with facilities before project kick off).
- Any additional work carried out without the express instruction of the project owner will not be paid for under the term on this contract and will be for the account of the contractor.
- Service provider shall dispose all used batteries and provide facilities with disposal certificate.
- DBSA does not have storage facility therefore service provider must provide own office and storage facility for new equipment and their tools.
- Contractor shall mount all logbook shelf on the wall. **NB: facilities to advice.**
- Contractor will be required to register all personnel with DBSA security before commencing with the service.

### 5. Warrantees and Guarantees

- One year on site repair or replace with factory authorized start up, from the date of the official handover, in accordance with DBSA general conditions of contract, it is reminded that any items

replaced will also carry a twelve (12) months warrantee from the successful recommissioning of that item and records of installation and dates of equipment must be held.

## 6. Safety requirements

- The contractor shall comply to DBSA Health and Safety procedures.
- Compile and submit health and safety plan on appointment.
- Compile and submit Baseline risk assessment on appointment.
- Submit Health and safety file after appointment for approval before commencing with the project.
- Applicable legal appointments letters (contractor) and agreement in terms of Section 37(2) of the OHS-Act.
- Attend OHS induction prior work commencement.
- Submit a valid Letter of Good Standing.
- The bank will not be responsible for any loss/damaged of tools on site.
- Perform a controlled shutdown to power down the existing equipment.

## 7. On site vendor requirements

- Provide proof of identification documents for workers before entering the DBSA campus.
- Site agent must report to facilities daily before project starts.
- Only personnel registered at the security will be allowed to work within the perimeters of the building.
- It is a definite requirement that a contractor shall only employ personnel fully conversant with the required service as per terms of reference.

## 8. Preparation of Proposal

**Each respondent is required to submit a proposal containing the following information:**

- Contractor must submit a detailed quotation as per scope of work.
- Overview of the company profile and experience.

## 9. Mandatory Requirements

### **Bidders must comply with**

- Signed and dated commissioning confirmation letter from the OEM (Original Equipment Manufacturer)
- Less than 70 disqualifications
- 2 years financial statements
- Provide proof of compensation liability cover (COIDA)
- Provide letter of good standing.
- Public liability 3 million
- Letter of intent from the manufacture, distributor, or bank guarantee letter from a recognized financial institution.
- Detailed quotation showing all required services.

## 1. Evaluation Criteria

Sub-Criteria	Description	Weightings
<b>Company must have five or more years' experience in installation and</b>	<ul style="list-style-type: none"> <li>• Provide a detailed company profile indicating experience in the following services. Supply and Installation of UPS systems completed within the last five years.</li> </ul>	<b>15</b>

Sub-Criteria	Description	Weightings
<b>commissioning of UPS systems.</b>	<ul style="list-style-type: none"> <li>• Please Note: A profile must indicate a list of five or more projects in relation to UPS systems in the last five years.</li> <li>• Experience: 5 or more projects = 15 points 3 to 4 projects =10 points 1 to 2 projects= 5 points</li> </ul>	
	<ul style="list-style-type: none"> <li>• Provide Four (4) signed and dated relevant contactable reference letters indicating work carried out or completed successfully in supply, installation and commissioning of UPS systems including data center(s) UPS within the last five years.</li> <li>• <b>Please Note:</b> Required reference letters must be on the relevant company letterhead, indicating, project amount duration of work and completion certificate. References provided in a list format and purchase order will not be recommended.</li> </ul> <p>4 or more references = 20 points 3 references = 15 points 2 references = 10 points 1 reference = 5 points</p>	<b>20</b>
<b>Qualifications, experience, and Capacity</b>	Provide a fully detailed CV, supported by certified qualification certificate of the following required site personnel indicating duties, skills performed, related current employer, previous employer and years of work experience in electrical heavy current filed.	
<b>Handyman CV accompanied by certified copies of Identity document: No. of years' experience: at least 5 years in build environment</b>	<b>Handyman:</b> <ul style="list-style-type: none"> <li>• Handyman with 5 years or more experience = 15 points</li> <li>• Handyman with 3 to 4 years' experience = 10 points</li> <li>• Handyman with 2 years' experience = 5 points</li> <li>• Handyman with 1 years' experience = 0</li> </ul>	<b>15</b>
<b>Trade tested Electrical Artisan with 3phase wireman's license recognized by the department of labor:</b>	<b>Qualified Trade Test Artisan/ Technician with 3 Phase installation license.</b> <ul style="list-style-type: none"> <li>• Electrical Artisan/ technician with 5 or more years' experience = 20 points</li> </ul>	<b>20</b>

<b>Sub-Criteria</b>	<b>Description</b>	<b>Weightings</b>
<b>Number of years of experience 5 years or more.</b>	<ul style="list-style-type: none"> <li>• Electrical Artisan/ Technician with 3 to 4 years' experience = 15 points</li> <li>• Electrical Artisan/ Technician with 2 years' experience = 10 points</li> <li>• Electrical Artisan/ Technician with 1 years' experience =5 points</li> </ul>	
<b>Site agent with Electrical Artisan certificate, minimum N3 certificate and wireman license</b>  <b>No. of years' experience: minimum 5 years in the relevant field</b>	<b>Qualified Site agent with 5 years build in environment experience.</b> <ul style="list-style-type: none"> <li>• Site agent with 5 years' experience or more = 20 points</li> <li>• Site agent with 3-4 years' experience = 15 points</li> <li>• Site agent with 2 years' experience = 10 points</li> <li>• Site agent with 1 years' experience = 5 points</li> </ul>	<b>20</b>
<b>Project Plan and timelines</b>	<ul style="list-style-type: none"> <li>• Provide a detailed project plan and timelines = 10 points</li> <li>• No detailed project plan = 0 points</li> </ul>	<b>10</b>
<b>Total</b>		<b>100</b>

NB: Bidders scoring less than 70% on functionality will not be further evaluated.

## 10. Reservations

### The DBSA expressly reserves the following rights:

- To waive any or all irregularities in the proposal submitted.
- To confirm pricing with the top three service providers before appointment.
- To negotiate price with the selected service provider.



## Annexure A

### Fees and Assumptions

This Annexure must be in folder 2 of your submission.

#### 11. BOQ

Item Description	ITEM	QTY	Unit Price (R)
1. 300KVA UPS.	Each	1	
2. 100KVA UPS	Each	1	
3. UPS 3M parallel maintenance bypass panel;	Each	1	
4. 1150K 12v batteries	Each	295	
5. Battery isolator 35Ka-380/415v AC...50Ka 250v DC	Each	1	
6. Battery cabinet for 50 batteries	Each	1	
7. 35mm supply cable (4C +E)	Each	120m	
8. 35mm supply cable (4C+E) from DB	Each	150m	
9. 95mm battery cable (links) and Lugs	Each	1000m	
10. 95mm Battery cable (links) and lugs	Each	1000m	
11. Rigging both new and the old UPSs	Sum	4	
12. UPS batteries disposal	Each	295	
13. Plant room Logbook shelf	Each	3	
14. Consumables	Sum		
15. Monthly UPS maintenance check and service for 300KVA units	Monthly	60	
16. Monthly UPS maintenance check and service for 100KVA units	Monthly	60	
17. Monthly UPS maintenance check and service for 80 KVA units at VA	Monthly	60	

18. 80Kva batteries at VA	Each	60	
19. commission the existing DB in the server room provide COC	Sum		
20. SU4 Flush DB	Each	1	
21. UPS service logbook	Each	2	
22. Logbook cabinet	Each	1	
23. Painting and renovation server room.	Each	75m <sup>2</sup>	
24. Ceiling grid and ceiling tiles server room	Each	75m <sup>2</sup>	
25. Painting and renovation UPS room wall and floor.	Each	26m <sup>2</sup>	
26. Ceiling grid and ceiling tiles UPS room	Each	26m <sup>2</sup>	
27. Painting of battery room wall and floor.	Each	336m <sup>2</sup>	
28. UPS service logbook VA	Each	3	
29. Logbook cabinet	Each	1	
30. Painting of server room.VA	Each	60m <sup>2</sup>	
31. Ceiling grid and ceiling tiles server room VA	Each	60m <sup>2</sup>	
32. Painting and renovation UPS room wall and floor.VA	Each	40m <sup>2</sup>	
33. Ceiling grid and ceiling tiles UPS room VA	Each	60m <sup>2</sup>	
34. Transport	Each		
35. Labour	Sum		
<b>Total Price</b>			
<b>Contingency 10%</b>			
<b>VAT (15%)</b>			
<b>Grand Total Price</b>			

## BIDDER’S DISCLOSURE

### 1. PURPOSE OF THE FORM

Any person (natural or juristic) may make an offer or offers in terms of this invitation to bid. In line with the principles of transparency, accountability, impartiality, and ethics as enshrined in the Constitution of the Republic of South Africa and further expressed in various pieces of legislation, it is required for the bidder to make this declaration in respect of the details required hereunder.

Where a person/s are listed in the Register for Tender Defaulters and / or the List of Restricted Suppliers, that person will automatically be disqualified from the bid process.

### 2. Bidder’s declaration

2.1 Is the bidder, or any of its directors / trustees / shareholders / members / partners or any person having a controlling interest<sup>1</sup> in the enterprise, employed by the state? **YES/NO**

2.1.1 If so, furnish particulars of the names, individual identity numbers, and, if applicable, state employee numbers of sole proprietor/ directors / trustees / shareholders / members/ partners or any person having a controlling interest in the enterprise, in table below.

Full Name	Identity Number	Name of State institution

---

<sup>1</sup> the power, by one person or a group of persons holding the majority of the equity of an enterprise, alternatively, the person/s having the deciding vote or power to influence or to direct the course and decisions of the enterprise.

2.2 Do you, or any person connected with the bidder, have a relationship with any person who is employed by the procuring institution? **YES/NO**

2.2.1 If so, furnish particulars:  
 .....  
 .....

2.3 Does the bidder or any of its directors / trustees / shareholders / members / partners or any person having a controlling interest in the enterprise have any interest in any other related enterprise whether or not they are bidding for this contract?**YES/NO**

2.3.1 If so, furnish particulars:  
 .....  
 .....

**3 DECLARATION**

I, \_\_\_\_\_ the \_\_\_\_\_ undersigned, (name)..... in submitting the accompanying bid, do hereby make the following statements that I certify to be true and complete in every respect:

- 3.1 I have read and I understand the contents of this disclosure;
- 3.2 I understand that the accompanying bid will be disqualified if this disclosure is found not to be true and complete in every respect;
- 3.3 The bidder has arrived at the accompanying bid independently from, and without consultation, communication, agreement or arrangement with any competitor. However, communication between partners in a joint venture or consortium<sup>2</sup> will not be construed as collusive bidding.
- 3.4 In addition, there have been no consultations, communications, agreements or arrangements with any competitor regarding the quality, quantity, specifications, prices, including methods, factors or formulas used to calculate prices, market allocation, the intention or decision to submit or not to submit the bid, bidding with the intention not to win the bid and conditions or delivery particulars of the products or services to which this bid invitation relates.
- 3.4 The terms of the accompanying bid have not been, and will not be, disclosed by the bidder, directly or indirectly, to any competitor, prior to the date and time of the official bid opening or of the awarding of the contract.

---

<sup>2</sup> Joint venture or Consortium means an association of persons for the purpose of combining their expertise, property, capital, efforts, skill and knowledge in an activity for the execution of a contract.

3.5 There have been no consultations, communications, agreements or arrangements made by the bidder with any official of the procuring institution in relation to this procurement process prior to and during the bidding process except to provide clarification on the bid submitted where so required by the institution; and the bidder was not involved in the drafting of the specifications or terms of reference for this bid.

3.6 I am aware that, in addition and without prejudice to any other remedy provided to combat any restrictive practices related to bids and contracts, bids that are suspicious will be reported to the Competition Commission for investigation and possible imposition of administrative penalties in terms of section 59 of the Competition Act No 89 of 1998 and or may be reported to the National Prosecuting Authority (NPA) for criminal investigation and or may be restricted from conducting business with the public sector for a period not exceeding ten (10) years in terms of the Prevention and Combating of Corrupt Activities Act No 12 of 2004 or any other applicable legislation.

I CERTIFY THAT THE INFORMATION FURNISHED IN PARAGRAPHS 1, 2 and 3 ABOVE IS CORRECT.

I ACCEPT THAT THE STATE MAY REJECT THE BID OR ACT AGAINST ME IN TERMS OF PARAGRAPH 6 OF PFMA SCM INSTRUCTION 03 OF 2021/22 ON PREVENTING AND COMBATING ABUSE IN THE SUPPLY CHAIN MANAGEMENT SYSTEM SHOULD THIS DECLARATION PROVE TO BE FALSE.

.....  
Signature Date

.....  
Position Name of bidder

## PREFERENCE POINTS CLAIM FORM IN TERMS OF THE PREFERENTIAL PROCUREMENT REGULATIONS 2022

This preference form must form part of all tenders invited. It contains general information and serves as a claim form for preference points for specific goals.

**NB: BEFORE COMPLETING THIS FORM, TENDERERS MUST STUDY THE GENERAL CONDITIONS, DEFINITIONS AND DIRECTIVES APPLICABLE IN RESPECT OF THE TENDER AND PREFERENTIAL PROCUREMENT REGULATIONS, 2022**

---

### 1. GENERAL CONDITIONS

1.1 The following preference point systems are applicable to invitations to tender:

- the 80/20 system for requirements with a Rand value of up to R50 000 000 (all applicable taxes included); and
- the 90/10 system for requirements with a Rand value above R50 000 000 (all applicable taxes included).

### 1.2 To be completed by the organ of state

*(delete whichever is not applicable for this tender).*

- a) The applicable preference point system for this tender is the **90/10** preference point system.
- b) The applicable preference point system for this tender is the **80/20** preference point system.
- c) Either the **90/10 or 80/20 preference point system** will be applicable in this tender. The lowest/ highest acceptable tender will be used to determine the accurate system once tenders are received.

1.3 Points for this tender (even in the case of a tender for income-generating contracts) shall be awarded for:

- (a) Price; and
- (b) Specific Goals (namely, BBBEE status level of contributor).

### 1.4 To be completed by the organ of state:

The maximum points for this tender are allocated as follows:

	POINTS
PRICE	
SPECIFIC GOALS	
<b>Total points for Price and SPECIFIC GOALS</b>	<b>100</b>

- 1.5 Failure on the part of a tenderer to submit proof or documentation required in terms of this tender to claim points for specific goals with the tender, will be interpreted to mean that preference points for specific goals are not claimed.
- 1.6 The organ of state reserves the right to require of a tenderer, either before a tender is adjudicated or at any time subsequently, to substantiate any claim in regard to preferences, in any manner required by the organ of state.

## 2. DEFINITIONS

- (a) **“tender”** means a written offer in the form determined by an organ of state in response to an invitation to provide goods or services through price quotations, competitive tendering process or any other method envisaged in legislation;
- (b) **“price”** means an amount of money tendered for goods or services, and includes all applicable taxes less all unconditional discounts;
- (c) **“rand value”** means the total estimated value of a contract in Rand, calculated at the time of bid invitation, and includes all applicable taxes;
- (d) **“tender for income-generating contracts”** means a written offer in the form determined by an organ of state in response to an invitation for the origination of income-generating contracts through any method envisaged in legislation that will result in a legal agreement between the organ of state and a third party that produces revenue for the organ of state, and includes, but is not limited to, leasing and disposal of assets and concession contracts, excluding direct sales and disposal of assets through public auctions; and
- (e) **“the Act”** means the Preferential Procurement Policy Framework Act, 2000 (Act No. 5 of 2000).

## 3. FORMULAE FOR PROCUREMENT OF GOODS AND SERVICES

### 3.1. POINTS AWARDED FOR PRICE

#### 3.1.1 THE 80/20 OR 90/10 PREFERENCE POINT SYSTEMS

A maximum of 80 or 90 points is allocated for price on the following basis:

$$\begin{array}{ccc}
 \mathbf{80/20} & \mathbf{or} & \mathbf{90/10} \\
 \\
 \mathbf{Ps = 80 \left( 1 - \frac{Pt - P_{min}}{P_{min}} \right)} & \mathbf{or} & \mathbf{Ps = 90 \left( 1 - \frac{Pt - P_{min}}{P_{min}} \right)}
 \end{array}$$

Where

Ps = Points scored for price of tender under consideration

Pt = Price of tender under consideration

Pmin = Price of lowest acceptable tender

### 3.2. FORMULAE FOR DISPOSAL OR LEASING OF STATE ASSETS AND INCOME GENERATING PROCUREMENT

#### 3.2.1. POINTS AWARDED FOR PRICE

A maximum of 80 or 90 points is allocated for price on the following basis:

$$Ps = 80 \left( 1 + \frac{Pt - P_{max}}{P_{max}} \right) \text{ or } Ps = 90 \left( 1 + \frac{Pt - P_{max}}{P_{max}} \right)$$

Where

Ps = Points scored for price of tender under consideration

Pt = Price of tender under consideration

Pmax = Price of highest acceptable tender

### 4. POINTS AWARDED FOR SPECIFIC GOALS

4.1. In terms of Regulation 4(2); 5(2); 6(2) and 7(2) of the Preferential Procurement Regulations, preference points must be awarded for specific goals stated in the tender. For the purposes of this tender the tenderer will be allocated points based on the goals stated in table 1 below as may be supported by proof/ documentation stated in the conditions of this tender:

4.2. In cases where organs of state intend to use Regulation 3(2) of the Regulations, which states that, if it is unclear whether the 80/20 or 90/10 preference point system applies, an organ of state must, in the tender documents, stipulate in the case of—

(a) an invitation for tender for income-generating contracts, that either the 80/20 or 90/10 preference point system will apply and that the highest acceptable tender will be used to determine the applicable preference point system; or

(b) any other invitation for tender, that either the 80/20 or 90/10 preference point system will apply and that the lowest acceptable tender will be used to determine the applicable preference point system,

then the organ of state must indicate the points allocated for specific goals for both the 90/10 and 80/20 preference point system.



**Table 1: Specific goals for the tender and points claimed are indicated per the table below.**

***(Note to organs of state: Where either the 90/10 or 80/20 preference point system is applicable, corresponding points must also be indicated as such.)***

***Note to tenderers: The tenderer must indicate how they claim points for each preference point system.)***

The specific goals allocated points in terms of this tender	Number of points allocated (90/10 system) (To be completed by the organ of state)	Number of points allocated (80/20 system) (To be completed by the organ of state)	Number of points claimed (90/10 system) (To be completed by the tenderer)	Number of points claimed (80/20 system) (To be completed by the tenderer)
1	10	20		
2	9	18		
3	6	14		
4	5	12		
5	4	8		
6	3	6		
7	2	4		
8	1	2		
Non-compliant contributor	0	0		

**(Note: Bidders are required to submit their BBBEE certificates or sworn affidavits (in the case of EMEs/QSEs) in order to be eligible to claim points)**

## DECLARATION WITH REGARD TO COMPANY/FIRM

4.3. Name \_\_\_\_\_ of  
company/firm.....

4.4. Company \_\_\_\_\_ registration \_\_\_\_\_ number:  
.....

### 4.5. TYPE OF COMPANY/ FIRM

Partnership/Joint Venture / Consortium

One-person business/sole propriety

Close corporation

Public Company

Personal Liability Company

(Pty) Limited

Non-Profit Company

State Owned Company

[TICK APPLICABLE BOX]

4.6. I, the undersigned, who is duly authorised to do so on behalf of the company/firm, certify that the points claimed, based on the specific goals as advised in the tender, qualifies the company/ firm for the preference(s) shown and I acknowledge that:

- i) The information furnished is true and correct;
- ii) The preference points claimed are in accordance with the General Conditions as indicated in paragraph 1 of this form;
- iii) In the event of a contract being awarded as a result of points claimed as shown in paragraphs 1.4 and 4.2, the contractor may be required to furnish documentary proof to the satisfaction of the organ of state that the claims are correct;
- iv) If the specific goals have been claimed or obtained on a fraudulent basis or any of the conditions of contract have not been fulfilled, the organ of state may, in addition to any other remedy it may have –
  - (a) disqualify the person from the tendering process;
  - (b) recover costs, losses or damages it has incurred or suffered as a result of that person's conduct;
  - (c) cancel the contract and claim any damages which it has suffered as a result of having to make less favourable arrangements due to such cancellation;
  - (d) recommend that the tenderer or contractor, its shareholders and directors, or only the shareholders and directors who acted on a fraudulent basis, be restricted from obtaining business from any organ of state for a period not exceeding 10 years, after the *audi*

- alteram partem* (hear the other side) rule has been applied; and
- (e) forward the matter for criminal prosecution, if deemed necessary.

<p>..... <b>SIGNATURE(S) OF TENDERER(S)</b></p>
<p><b>SURNAME AND NAME:</b> .....</p>
<p><b>DATE:</b>.....</p>
<p><b>ADDRESS:</b>.....</p>
<p>.....</p>
<p>.....</p>
<p>.....</p>

## RESTRICTED SUPPLIERS

- 1 In order to give effect to the above, the following questionnaire must be completed and submitted with the bid.

Item	Question	Yes	No
4.1	<p><b>Is the bidder or any of its directors listed on the National Treasury’s Database of Restricted Suppliers as companies or persons prohibited from doing business with the public sector?</b> (Companies or persons who are listed on this Database were informed in writing of this restriction by the Accounting Officer/Authority of the institution that imposed the restriction after the <i>audi alteram partem</i> rule was applied).</p> <p><b>The Database of Restricted Suppliers now resides on the National Treasury’s website(<a href="http://www.treasury.gov.za">www.treasury.gov.za</a>) and can be accessed by clicking on its link at the bottom of the home page.</b></p>	Yes <input type="checkbox"/>	No <input type="checkbox"/>
4.1.1	If so, furnish particulars:		
4.2	<p>Is the bidder or any of its directors listed on the Register for Tender Defaulters in terms of section 29 of the Prevention and Combating of Corrupt Activities Act (No 12 of 2004)?</p> <p><b>The Register for Tender Defaulters can be accessed on the National Treasury’s website (<a href="http://www.treasury.gov.za">www.treasury.gov.za</a>) by clicking on its link at the bottom of the home page.</b></p>	Yes <input type="checkbox"/>	No <input type="checkbox"/>
4.2.1	If so, furnish particulars:		
4.3	Was the bidder or any of its directors convicted by a court of law (including a court outside of the Republic of South Africa) for fraud or corruption during the past five years?	Yes <input type="checkbox"/>	No <input type="checkbox"/>
4.3.1	If so, furnish particulars:		
4.4	Was any contract between the bidder and any organ of state terminated during the past five years on account of failure to perform on or comply with the contract?	Yes <input type="checkbox"/>	No <input type="checkbox"/>
4.4.1	If so, furnish particulars:		

## **Annexure D**

**Bidders are required to include, as Annexure F to their Bids, certified copies of all relevant CIPC registration documents listing all members with percentages, in the case of a close corporation**

## **Annexure E**

**Bidders are required, as annexure G to their Bids, to submit certified copies of the latest share certificates of all relevant companies**

## **Annexure F**

**Bidders which submit Bids as an unincorporated joint venture, consortium or other association of persons are required to submit, as Annexure H, a breakdown of how the percentage (%) fees and work will be split between the various people or entities which constitute the Bidder.**

## **Annexure G**

**Bidders are required to include, as Annexure I to their Bids, supporting documents to their responses to the Pre- Qualifying Criteria and Evaluation Criteria.**

**Where the supporting document is the profile of a member of the Bidder's proposed team, this should be indicated.**



**Annexure H**

**[General Conditions of Contract]**

**PLEASE NOTE THAT ALL BIDDERS ARE REQUIRED TO READ THROUGH THE GENERAL CONDITIONS OF CONTRACT PRESCRIBED BY THE NATIONAL TREASURY. SUCH GENERAL CONDITIONS OF CONTRACT CAN BE ACCESSED ON THE NATIONAL TREASURY WEBSITE.**

**PLEASE NOTE FURTHER THAT ALL BIDDERS MUST ENSURE THAT THEY ARE WELL ACQUAINTED WITH THE RIGHTS AND OBLIGATIONS OF ALL PARTIES INVOLVED IN DOING BUSINESS WITH GOVERNMENT.**

NOTE: All Bidders are required to confirm (*Tick applicable box*) below:

<b>Item</b>	<b>YES</b>	<b>NO</b>
Is the Bidder familiar with the General Conditions of Contract prescribed by the National Treasury?		

## Annexure I

### Tax Compliant Status and CSD Registration Requirements

**ALL PROSPECTIVE BIDDERS MUST HAVE A TAX COMPLIANT STATUS EITHER ON THE CENTRAL SUPPLIER DATABASE (CSD) OF THE NATIONAL TREASURY OR SARS E FILING PRIOR TO APPOINTMENT/AWARD OF THE BID.**

**REGISTRATION ON THE CSD SITE OF THE NATIONAL TREASURY IS A COMPULSORY REQUIREMENT FOR A BIDDER TO BE APPOINTED, TO CONDUCT BUSINESS WITH THE DBSA. THE ONUS IS ON THE SUCCESSFUL BIDDER TO REGISTER ON THE CSD SITE AND PROVIDE PROOF OF SUCH REGISTRATION PRIOR TO APPOINTMENT/AWARD OF THE BID.**

**CSD Registration Number:**



The Development Bank of Southern Africa has a Zero Tolerance on Fraud and Corruption. Report any incidents of Fraud and Corruption to Whistle Blowers on any of the following:

TollFree : 0800 20 49 33  
Email : [dbsa@whistleblowing.co.za](mailto:dbsa@whistleblowing.co.za)  
Free Post : Free Post KZN 665 | Musgrave | 4062  
SMS : 33490